

DETAIL DESIGN PROGRESS VISUALS

North Wing Collaboration

Removing existing individual team desk space to create a new informal collaborative environment. A range of bookable spaces for various sized groups to come to together, carry out meetings and brainstorm ideas within a relaxed collaboration space.



Proposal illustrations for 1st floor North Wing Collaboration





Birdseye view of how the collaboration floor will look.

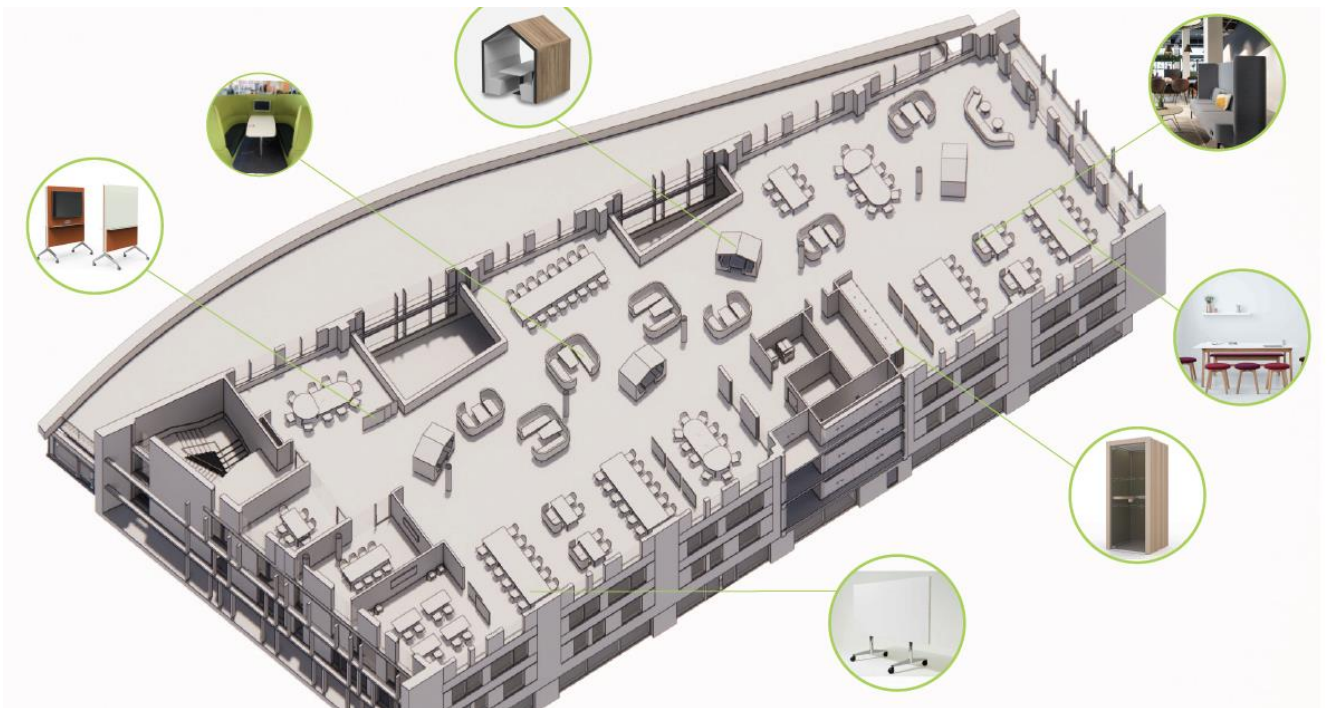

Call Booth proposal

Transforming existing tea points to individual call booths across all floors to enable employees to join Zoom/Teams calls away from their desks with acoustic partitions and sound baffles.

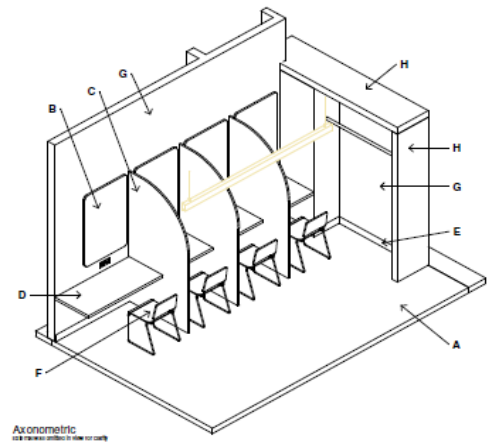
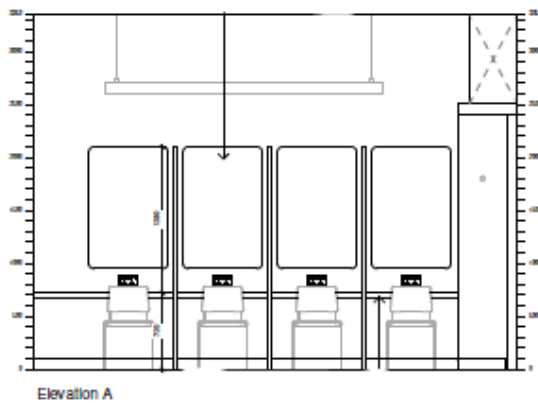

Refreshment zones

Removing floor tea points and replacing with larger refreshment zones on each individual floor. The areas will be used to promote collaboration and networking and there will be a breakaway space to have coffee and eat with colleagues. Members of staff can choose to work where suits them best.

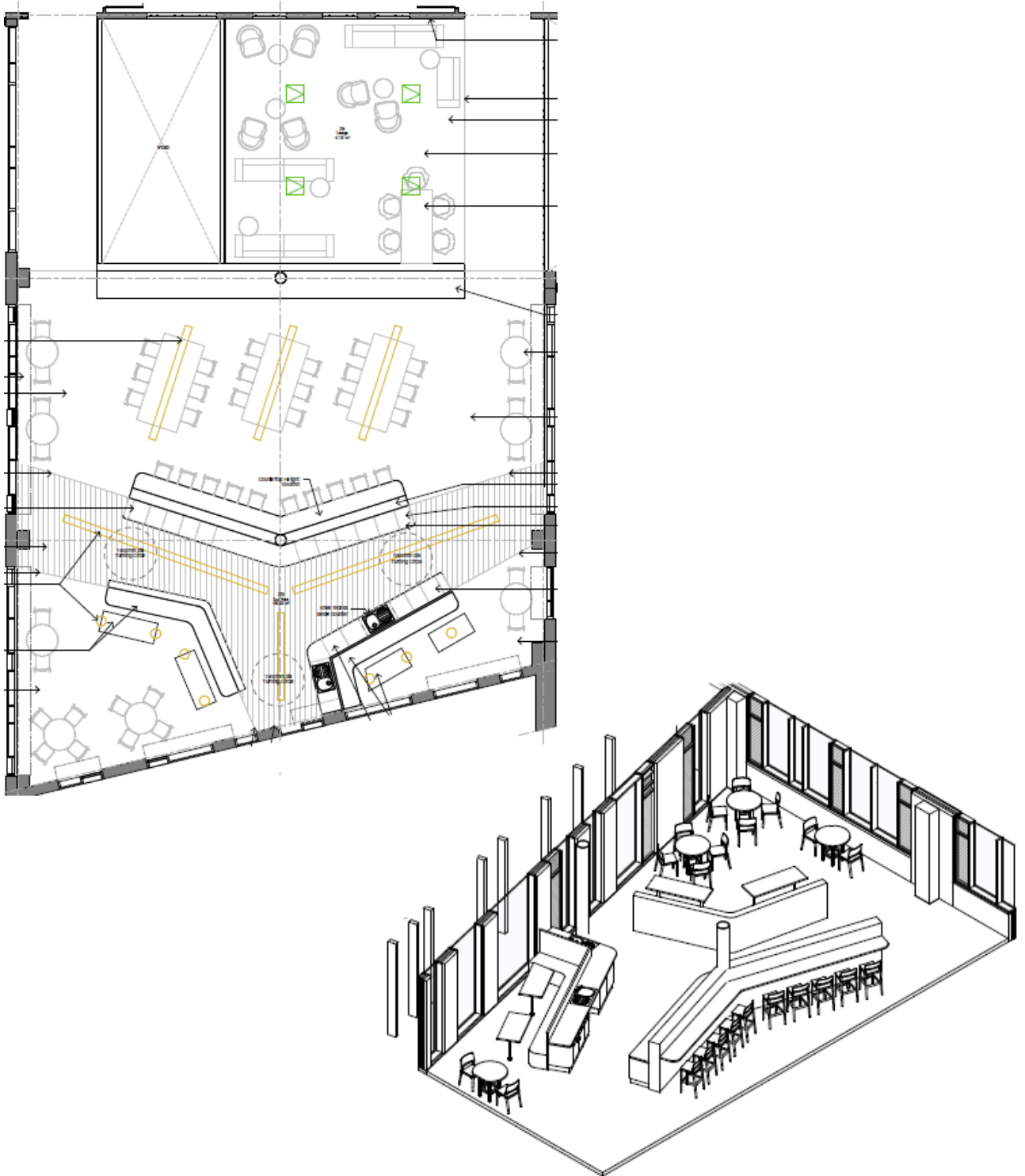

Collaboration and Hot-desk zones

Bookable spaces throughout the central and South Wings of the building to allow employees to work collaboratively or simply work alone in a relaxed open environment. Adding soft furnishings, digital equipment and graphics throughout the office to create a relaxed, productive and agile working environment.



New balcony working spaces located in the South Wing with an acoustic partitioning to mitigate noise transfer through to hot desk areas behind, along with relaxed working lounge space in the centre zones of the building to relax, work and meet colleagues.



Reception lounge / Partner hub

Transforming the reception lobby into a vibrant working space that is open to employees, external partners, and project colleagues both to work and relax in a casual open forum. The area will be fitted with soft furnishings, power and data and accompanied by seating for visitors.

